

■ PROGRAMMABLE LOGIC CONTROLLER

■ HMI

■ MULTI-CHANNEL INTELLIGENT THERMOSTAT

Product Catalogue

Enterprise visions: To become a leading international supplier of new energy and automation products and solutions!

Enterprise missions: Green, intelligent, achieve a better life!

Core values: Customer-centred, open and pragmatic, collective struggle!



Shenzhen V&T Technologies Co.,Ltd.

Chinese version: VX-20230820-H-1.0 (BOM: 37110299) First Printing
The content of the product user manual shall prevail, subject to change without notice;
All rights reserved, any unauthorized copying and plagiarism are prohibited.

Shenzhen V&T Technologies Co., Ltd.

Headquarters Address: 3-8th Floor, Tower 2, Zhiyan Innovation Building, Yutang Street, Tianliao Community, Guangming District, Shenzhen, Guangdong Province, China.

Post code: 518107

Service Department Tel: (+86) 0755-26580830

Overseas Department Tel: (+86) 0755-2904-3763

Fax: (+86) 0755-26580821

Overseas Department Email: overseas@v-t.net.cn

Overseas website: www.vectorque.com

Chinese website: www.v-t.com



Wechat: lanhaihuateng



CHINA SHENZHEN

About V&T

Shenzhen V&T Technologies Co.,Ltd. is a state-level high-tech enterprise with completely independent intellectual property rights. We successfully listed on GEM in 2016, stock code: 300484. We adhere to the corporate culture of "pioneering, innovation, integrity, pragmatic", and the business philosophy of "creating value for customers, employees, enterprises and society" to contribute to the development of China's industrial equipment manufacturing industry and new energy industry. In recent years, we continue to maintain the leading level of core technology, to participate in the international mainstream brand competition, to provide advanced industrial automation control, new energy products and industrial system solutions, to quickly and effectively meet the diversified and individualized design needs of high-end customers, to create value for our customers, to build a win-win co-operation, and to contribute to the development of China's industrial equipment manufacturing to achieve high-efficiency, environmentally friendly, energy-saving automation product upgrades and the development of the new energy industry.

VT.Sysin

is a secondary trademark of V&T for industrial control system products, which will be used for the promotion of diversified products and industrial control system solutions, such as frequency inverter, PLC, HMI, servo system, motion control, and so on.



Powering Industrial Automation



Moving Forward Without End



Build Win-Win Cooperation

Providing core components and solutions for the industrial automation industry
Moving Forward Without End

2006

- Formation of the corporate structure
- Technology upgrading
- Product platform construction

2007

- Release of vector torque control inverter
- Shenzhen Software Enterprise

2008-2009

- Open-loop torque control technology
- CE certification
- Shenzhen High-Tech Enterprise
- Entered the new energy vehicle industry

2010-2011

- Obtained the certification of "National High-Tech Enterprise"
- Completed shareholding conversion

2014-2015

- Electric vehicle motor controller performance growth
- Passed the automotive industry quality system certification

2016

- 10th Anniversary of the Company
- Completed listing on the GEM board of the Shenzhen Stock Exchange

2017-2018

- Xiamen V&T Industrial Park put into use
- Wuxi V&T R&D Centre put into use
- Awarded the title of Top 100 Taxpaying Enterprises in Nanshan District, Shenzhen City
- Awarded the title of Leading Enterprise by Shenzhen Nanshan District People's Government

2019

- Launched the AIEC series of elevator products
- Released V9-H series general-purpose inverters
- Released VTS general-purpose inverter/servo drive

2020

- Launched VC series PLC products and touch screens.
- Domestic and overseas sales of AIEC series elevator products
- Established Guangdong new energy vehicle drive and control engineering technology research centre
- Awarded postdoctoral innovation practice base

2021-2022

- Introduced DP-2000 series touch screen products
- Launched multi-channel intelligent thermostats
- Entered the semiconductor industry to create an industrial ecological pattern of complementary advantages and win-win co-operation with the upstream and downstream of the industry chain

PLC Product Profile

VC10 series programmable logic controller (PLC) is a general-purpose economic PLC, with features of compact structure, powerful functions, large program capacity; with functions of data processing, analogue processing, Modbus network communication, floating-point arithmetic, high-speed counting and pulse output positioning control. It can be widely used in textile, chemical fibre, machine tool, cable, food, beverage, packaging, plastic steel, construction machinery, brick machine, stone, air conditioning, lift, printing, electronic equipment, pharmaceutical equipment and other industries.

VC10V series is a simple motion programmable logic controller with 4-channel pulse outputs based on VC10 series, built-in 2-channel 100KHz + 2-channel 60KHz high-speed pulse outputs, 2-channel 50KHz high-speed counting. It has all the functions of the VC10 with optimized and enhanced product performance, offering an excellent price-performance ratio.

VC20 series is a high-performance general-purpose small PLC, with powerful I/O extension capabilities and communication networking functions. It can be used for high-speed data processing and analogue processing, with capabilities of high stability, high reliability, high-capacity, high-speed computing. It's powerful and cost-effective, widely used in machine tools, construction machinery, textile, printing, metal processing, wire drawing equipment, plastic machinery, air conditioning, heating and ventilating(HVAC), food and beverage, engineering machinery, electronic equipment, underground, lift, pharmaceutical equipment and other industries.

VC20H series is a high-performance motion control PLC that integrates 8×100KHz high-speed counting functions and up to 6-channel high-speed pulse outputs with frequencies up to 200KHz, programme storage capacity can be up to 32K. With functions of linear interpolation, circular interpolation, synchronous following, electronic gears and so on, it can achieve positioning control, trajectory control and synchronous motion control, suitable for robotics, textile, printing, dyeing and finishing, packaging, machine tools, woodworking machinery and other industries.

Product Features

High stability, high reliability

- Wide input voltage design, input voltage range AC85V~280V.
- Unique three-proof protection process designed for the harsh industrial application environment in China.
- User programmes are stored in EEPROM for stable and permanent storage.

High computing speed, large capacity, strong extension capability

- Ultra-high computing speed, the fastest basic instruction can be up to 0.065μs.
- Large programme capacity, the max. capacity of the host computer can be up to 32K.
- Superior I/O extension performance, the max. extension can be up to 512 points.

High safety

- Multi-level password protection, you can set the data to modify monitoring password, upload and download password, sub-program encryption.
- Up to 8-digit password design to ensure programme security and prohibit unauthorized copying.
- Password verification can set the number of retries.
- Independent download software, you can download the programme code directly without opening it, avoiding the programme code being changed and programme leakage.

Open and practical network

- RS232/RS485 communication interface is standard on the host, supporting Modbus protocol and free-port protocol.
- High-speed N:N network bus supports up to 32 stations.

PLC Product Series

Item	VC10	VC10V	VC20	VC20H
Master module	16/24/30/40/60	16/24/30/40/60	64/80	32
Master module communication	RS232 1pcs, RS232/RS485 1pcs	RS232 1pcs, RS485 2pcs	RS232 1pcs, RS232/RS485 1pcs	RS232 1pcs, RS485 2pcs
Extension module	Expandable with 7 modules, I/O up to 172 points	Expandable with 7 modules, I/O up to 172 points	Expandable with 8 special modules, I/O up to 512 points	
Program capacity	12K steps	16K steps	12K steps	32K steps
Basic instruction computing speed	0.3 μs	0.3μs	0.09μs	0.065μs
Internal relay(M)	2048 points (M0-M2047)	2048 points (M0-M2047)	2000 points (M0-M1999)	10240 points (M0- M10239)
Internal register(D)	8000 points (D0-D7999)	8000 points (D0-D7999)	8000 points (D0-D7999)	8000 points (D0-D7999), 32768 points (R0-R32767)
Timer	256 points(T0 -T255), T0-T209: 100ms, T210-T251: 10ms, T252-T255: 1ms,			512 points: T0-T209: 100ms, T210-T479: 10ms, T480-T511: 1ms
Counter	256points(C0-C255), C0-C199: 16-bit incremental counting, C200-C235: 32-bit increment/decrement counting, C236-C255 : 32-bit high speed counting(of which, VC20H: C236-C255, C301-C306: 32-bit high-speed counting, total 262 points)			
High-speed counter	Single phase: 6 sets, 2×50KHz, 4×10KHz; AB two-phase: 2 sets, 1×30KHz, 1×5KHz; Simultaneous input frequency sum less than 60KHz			Single phase: 8×100KHz; AB two-phase: 4×50KHz, support 4 quad frequency
High-speed pulse output	2-channel independent 100KHz	2-channel independent 100KHz+ 2-channel independent 60KHz	2-channel independent 100KHz	4 axes up to 200KHz, 4 individual 100KHz, supports interpolation, electronic gears
Interrupt	Supports external input interrupt, timing interrupt, high-speed counting interrupt, communication interrupt, power loss interrupt			Supports high-speed output completion, interpolation and passing position interrupts in addition to all VC20 interrupts
Extension RS485 communication	No	No	Yes	Yes
Calendar clock	Yes	Yes	Yes	Yes
Power-off retention register	320pcs bit elements, 180pcs word elements, EEPROM	500pcs bit elements, 650pcs word elements, EEPROM	M, S, D, C, T Holds infinite range, requires battery support	
Floating-point operation	Yes	Yes	Yes	Yes

VC10 Series General Purpose Economic PLC



VC10 series is a general-purpose economic small PLC, with features of compact structure, powerful functions, large program capacity; with functions of data processing, analogue processing, Modbus network communication, floating-point arithmetic, high-speed counting and pulse output positioning control. It can be widely used in textile, chemical fibre, machine tool, cable, food, beverage, packaging, plastic steel, construction machinery, brick machine, stone, air conditioning, elevator, printing, electronic equipment, pharmaceutical equipment and other industries.

Small machine, high configuration, large capacity, high speed

- Integrated analogue inputs and outputs with a program capacity of 12K, the basic instruction only needs 0.3 us, it can be extended by 7 modules.

Powerful positioning and high-speed processing

- Positioning instruction for position control of machines.
- Variable-speed pulse outputs, including pulse outputs function, to achieve multi-step variable-speed control of servo or stepper motors.
- Built-in high-speed processing: 6-channel high-speed pulse inputs, max. frequency is 50KHz; 2-channel 100KHz high-speed pulse outputs.

Abundant interruption resources

- Support communication interruption, pulse interruption, power loss interruption, and can set the prior interruption to achieve advanced control.

Powerful communication networking capability

- Support N:N network communication protocol and OPC service.

Convenient and practical features

- Provide special function module configuration, inverter communication instructions, making complex programming simple.
- Provide system configuration verification tool, convenient for users to extend the configuration.

Safer, more stable and more reliable

- 8-bit password protection, can be set to prohibit the uploading of programs to prevent unauthorized copying.
- Ultra-wide voltage design, three-proof processing, input filtering and power-off retention register functions to ensure that the PLC is more stable and reliable.

VC 10 - 24 16 B R A 1

VC	V&T programmable logic controller sign VC: V&T Programmable Logic Controller	Sign	Special function information
Sign	Series explanation	1	Integrated 2 in 1 out analogue
10	Small general-purpose economic series	Other	Reserve
Other	Reserve	Default	Standard machine can be defaulted
Sign	Input points	Sign	Power type
10	10 points input	A	AC220V power supply
14	14 points input	D	DC24V power supply
16	16 points input	N	No external power input
24	24 points input	Sign	Output modes
36	36 points input	R	Relay output
...	...points input	T	Transistor output
Sign	Output points	N	No output
10	10 points output	Sign	Module type
14	14 points output	B	CPU master module
16	16 points output		
24	24 points output		
...	...points output		

Selection Chart

Master Module

Product series	Product model	Description	Size
VC10	VC10-1006BRA	VC10 series 10-point input 6-point relay output master module (AC power)	135×90×71.2
VC10	VC10-1006BTA	VC10 series 10-point input 6-point transistor output master module (AC power)	135×90×71.2
VC10	VC10-1410BRA	VC10 series 14-point input 10-point relay output master module (AC power)	135×90×71.2
VC10	VC10-1410BTA	VC10 series 14-point input 10-point transistor output master module (AC power)	135×90×71.2
VC10	VC10-1614BRA	VC10 series 16-point input 14-point relay output master module (AC power)	150×90×71.2
VC10	VC10-1614BTA	VC10 series 16-point input 14-point transistor output master module (AC power)	150×90×71.2
VC10	VC10-1614BRA1	16-point input and 14-point relay output master module with integrated 2 in 1 out analogue function (AC power)	182×90×71.2
VC10	VC10-1614BTA1	16-point input and 14-point transistor output master module with integrated 2 in 1 out analogue function (AC power)	182×90×71.2
VC10	VC10-2416BRA	VC10 series 24-point input 16-point relay output master module (AC power)	182×90×71.2
VC10	VC10-2416BTA	VC10 series 24-point input 16-point transistor output master module (AC power)	182×90×71.2
VC10	VC10-3624BRA	VC10 series 36-point input 24-point relay output master module (AC power)	224.5×90×79.2
VC10	VC10-3624BTA	VC10 series 36-point input 24-point transistor output master module (AC power)	224.5×90×79.2

I/O Extension Module

Product series	Product model	Description	Size
VC10	VC10-0808ERN	VC10 series 8-point input 8-point relay output extension module	61×90×71.2
VC10	VC10-0808ETN	VC10 series 8-point input 8-point transistor output extension module	61×90×71.2
VC10	VC10-1600ENN	VC10 series 16-point input extension module	61×90×71.2
VC10	VC10-0016ETN	VC10 series 16-point transistor output extension module	61×90×71.2
VC10	VC10-0016ERN	VC10 series 16-point relay output extension module	61×90×71.2

Special Function Module

Product series	Product model	Description	Size
VC10	VC10-4AD	VC10 series 4-channel analogue input module	61×90×71.2
VC10	VC10-4DA	VC10 series 4-channel analogue output module	61×90×71.2
VC10	VC10-4TC	VC10 series 4-channel thermocouple module	61×90×71.2
VC10	VC10-4PT	VC10 series 4-channel RTD module	61×90×71.2
VC10	VC10-5AM	VC10 series 4-channel analogue input, 1-channel analogue output	61×90×71.2

Specifications and Technical Specifications

Master Module General Specifications

Item	Description
Rated voltage	100-240VAC/24VDC
Allowable voltage range	85-264VAC/19-30VDC
Operating environment temperature	-5~55°C, 10~90%(non-condensing)
Storage environment temperature	-40~70°C, 10-90%(non-condensing)
Protection level	IP20
Safety certification	Designed in accordance with IEC61131-2 and UL508 standards, CE certified

Master Module Output Interface Specifications

Item	Relay output port	Transistor output port
External power	250VAC, under 30VDC	5~24VDC
Circuit insulation	By relay	Photocoupler
Motion indication	Relay output contacts closed, LED on	Photocoupler is driven, LED on
Leakage current of open circuit	/	Less than 0.1mA/30VDC
Min. load	2mA/5VDC	5mA(5~24VDC)
Max. output current	Resistive load	Y0、Y1: 0.3A/1 point Other: 0.3A/1 point 0.8A/4-point 1.2A/6-point 1.6A/8-point Above 8 points, total current increases 0.1A at each point increase
	Inductive load	220VAC, 80VAC Y0、Y1: 7.2W/24VDC Others: 12W/24VDC
	Illumination load	220VAC, 100W Y0、Y1: 0.9W/24VDC Others: 1.5W/24VDC
Response time	ON→OFF	20ms Max. Y0、Y1: 10 μs Others: 0.5ms
	OFF→ON	20ms Max.
Output common terminal	Y0-COM0; Y1-COM1; After Y2, up to 1 common terminal for every 8 terminals, each common isolated from each other	
Fuse protection	No	

Master Module Main Performance Specifications

Item	Description	
Implementation method	Cyclic scanning + interrupt method	
Programming method	Instruction, ladder diagram, sequential function diagram	
Instruction type	Basic instruction	32pcs
	Application instruction	226pcs
Implementation time	Basic instruction	0.3 μs
	Application instruction	Several μs~Hundreds of μs
Program capacity	12K steps	
Maximum extension	7 extension modules, including I/O extension and special function module	
Input relay (X)	X0~X177, 128 points, octal code	
Output relay (Y)	Y0~Y177, 128 points, octal code	
Auxiliary relay (M)	M0 ~M2047, 2048 points	
Local auxiliary relay (LM)	LM0 ~ LM63, 64 points	
Special auxiliary relay (SM)	SM0~SM255, 256 points	
Status relay(S)	S0-S1023, 1024 points	
Timer (T)	256 points(T0 ~ T255)	100ms precision:T0~T209, 210pcs
		10ms precision:T210-T251,42pcs
		1ms precision:T252~T255, 4pcs
Counter (C)	256 points(C0 ~C255)	16-bit incremental count:C0~C199, 200pcs
		32-bit increment/decrement count: C200-C235, 36pcs
		32-bit high speed count:C236-C255, 20pcs
Data register (D)	D0-D7999, 8000 points	
Local data register(V)	V0~V63, 64 points	
Variable address register(Z)	Z0~Z15, 16 points	
Special data register(SD)	SD0-SD255, 256 points	
Power-off retention register	M, S, D, C components can be saved, 320pcsbit components, 180pcs word components	
Storage media	EEPROM+FLASH	
High-speed counter	Single phase: 6 sets, 2×50KHz+4×10KHz	
	Two-phase: 2 sets, 1×30KHz+1×5KHz	
Pulse output	Y0~Y1, 2-channel independent 100KHz output	
Interruption resource	External input interrupt	16pcs (X0~X7, 8-channel support for rising and falling edges)
	High-speed count interrupt	6pcs
	Timed interrupt	3pcs
	Communication interrupt	8pcs
	Pulse interrupt	2pcs
Power loss interruption	1pcs	
Analogue potentiometer input	2pcs(0-255)	
Pulse capture	8-channel, X0-X1: 20μs, X2-X7: 100μs	
Digital filtering	X0-X7 are capable of digital filtering, filtering time (ms): 0, 8, 16, 32, 64. Others are capable of hardware filtering	
Communication port	3-channel (2-channel are RS-232, 1 channel is RS-232 / RS -485 optional)	

VC10V Simple Motion Small PLC



VC10V series is a simple motion control PLC, is a simple sport programmable logic controller with 4 pulse outputs based on the VC10 series, built-in 2-channel 100KHz + 2-channel 60KHz high-speed pulse outputs, 2-channel 50KHz high-speed counting. It has all the functions of VC10, and optimizes and improves the performance of VC10, making it extremely cost-effective.

Features

- Control scale (I/O): 16-172 points (Basic unit 16/24/30/40/60)
- It has all the functions of VC10 and optimizes the performance of VC10
- Built-in 2-channel 100KHz+2-channel 60KHz pulse output
- Built-in 2-channel 50KHz+4-channel 10KHz high-speed counting
- Comes with 3 communication ports (1 channel RS232 programming port, 2-channel RS485)
- Excellent expandability, extension unit see VC10 extension section

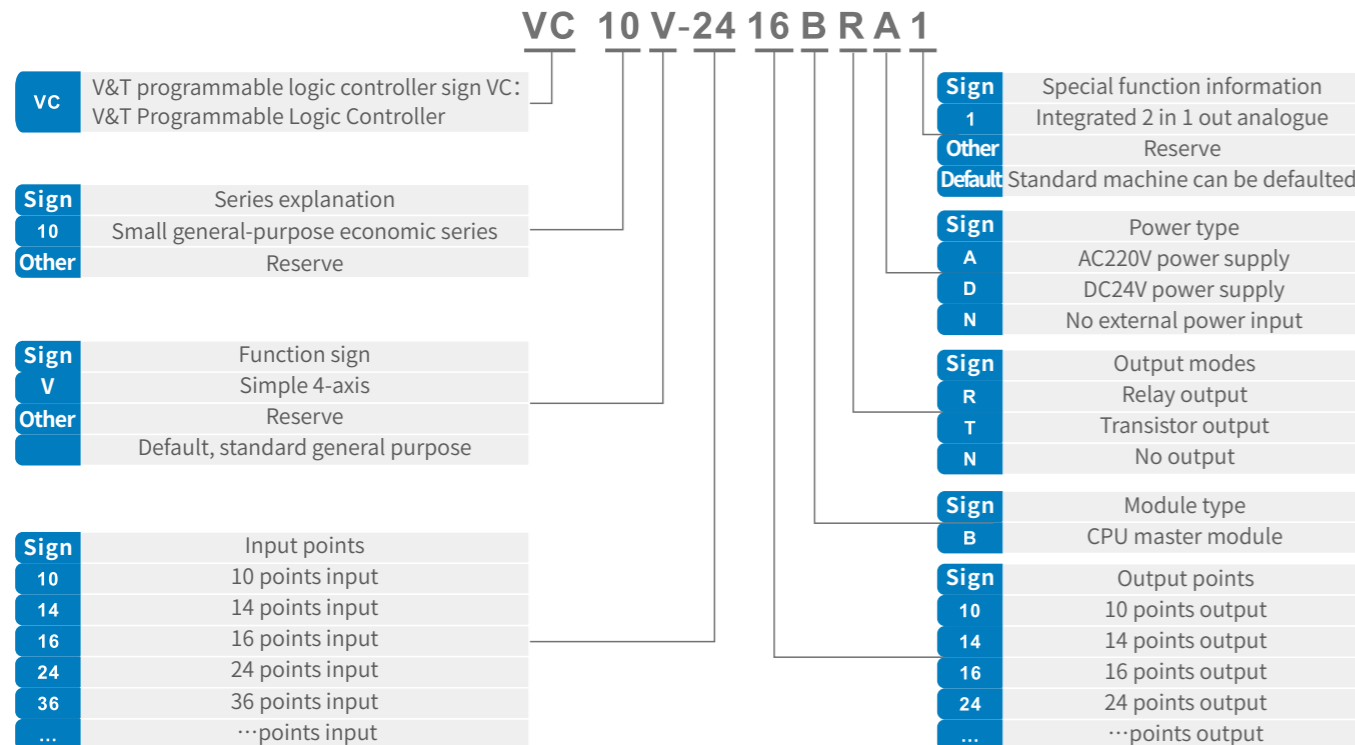

Selection Chart

Master Module

Product series	Product model	Description	Size
VC10	VC10-1006BRA	VC10 series 10-point input 6-point relay output master module (AC power)	135×90×71.2
VC10	VC10-1006BTA	VC10 series 10-point input 6-point transistor output master module (AC power)	135×90×71.2
VC10	VC10-1410BRA	VC10 series 14-point input 10-point relay output master module (AC power)	135×90×71.2
VC10	VC10-1410BTA	VC10 series 14-point input 10-point transistor output master module (AC power)	135×90×71.2
VC10	VC10-1614BRA	VC10 series 16-point input 14-point relay output master module (AC power)	150×90×71.2
VC10	VC10-1614BTA	VC10 series 16-point input 14-point transistor output master module (AC power)	150×90×71.2
VC10	VC10-1614BRA1	16-point input and 14-point relay output master module with integrated 2 in 1 out analogue function (AC power)	182×90×71.2
VC10	VC10-1614BTA1	16-point input and 14-point transistor output master module with integrated 2 in 1 out analogue function (AC power)	182×90×71.2
VC10	VC10-2416BRA	VC10 series 24-point input 16-point relay output master module (AC power)	182×90×71.2
VC10	VC10-2416BTA	VC10 series 24-point input 16-point transistor output master module (AC power)	182×90×71.2
VC10	VC10-3624BRA	VC10 series 36-point input 24-point relay output master module (AC power)	224.5×90×79.2
VC10	VC10-3624BTA	VC10 series 36-point input 24-point transistor output master module (AC power)	224.5×90×79.2

I/O Extension Module

Product series	Product model	Description	Size
VC10	VC10-0808ERN	VC10 series 8-point input 8-point relay output extension module	61×90×71.2
VC10	VC10-0808ETN	VC10 series 8-point input 8-point transistor output extension module	61×90×71.2
VC10	VC10-1600ENN	VC10 series 16-point input extension module	61×90×71.2
VC10	VC10-0016ETN	VC10 series 16-point transistor output extension module	61×90×71.2
VC10	VC10-0016ERN	VC10 series 16-point relay output extension module	61×90×71.2

Special Function Module

Product series	Product model	Description	Size
VC10	VC10-4AD	VC10 series 4-channel analogue input module	61×90×71.2
VC10	VC10-4DA	VC10 series 4-channel analogue output module	61×90×71.2
VC10	VC10-4TC	VC10 series 4-channel thermocouple module	61×90×71.2
VC10	VC10-4PT	VC10 series 4-channel RTD module	61×90×71.2
VC10	VC10-5AM	VC10 series 4-channel analogue input, 1-channel analogue output	61×90×71.2

Specifications and Technical Specifications

Master Module General Specifications

Item	Description
Rated voltage	100-240VAC/24VDC
Allowable voltage range	85-264VAC/19-30VDC
Operating environment temperature	-5~55°C, 10~90%(non-condensing)
Storage environment temperature	-40~70°C, 10-90%(non-condensing)
Protection level	IP20
Safety certification	Designed in accordance with IEC61131-2 and UL508 standards, CE certified

Master Module Output Interface Specifications

Item	Relay output port	Transistor output port
External power	250VAC, under 30VDC	5~24VDC
Circuit insulation	By relay	Photocoupler
Motion indication	Relay output contacts closed, LED on	Photocoupler is driven , LED on
Leakage current of open circuit	/	Less than 0.1mA/30VDC
Min. load	2mA/5VDC	5mA(5~24VDC)
Max. output current	Resistive load	Y0、Y1: 0.3A/1 point Other: 0.3A/1 point 0.8A/4-point 1.2A/6-point 1.6A/8-point Above 8 points, total current increases 0.1A at each point increase
	Inductive load	220VAC, 80VAC Y0、Y1: 7.2W/24VDC Others: 12W/24VDC
	Illumination load	220VAC, 100W Y0、Y1: 0.9W/24VDC Others: 1.5W/24VDC
Response time	ON→OFF	20ms Max. Y0、Y1: 10 μs Others: 0.5ms
	OFF→ON	20ms Max.
Output common terminal	Y0-COM0; Y1-COM1; After Y2, up to 1 common terminal for every 8 terminals, each common isolated from each other	
Fuse protection	No	

Master Module Main Performance Specifications

Item	Description	
Implementation method	Cyclic scanning + interrupt method	
Programming method	Instruction, ladder diagram, sequential function diagram	
Instruction type	Basic instruction	32pcs
	Application instruction	226pcs
Implementation time	Basic instruction	0.3 μs
	Application instruction	Several μs~Hundreds of μs
Program capacity	12K steps	
Maximum extension	7 extension modules, including I/O extension and special function module	
Input relay (X)	X0~X177, 128 points, octal code	
Output relay (Y)	Y0~Y177, 128 points, octal code	
Auxiliary relay (M)	M0 ~M2047, 2048 points	
Local auxiliary relay (LM)	LM0 ~ LM63, 64 points	
Special auxiliary relay (SM)	SM0~SM255, 256 points	
Status relay(S)	S0-S1023, 1024 points	
Timer (T)	256 points(T0 ~ T255)	100ms precision:T0~T209, 210pcs
		10ms precision:T210-T251,42pcs
		1ms precision:T252~T255, 4pcs
Counter (C)	256 points(C0 ~C255)	16-bit incremental count:C0~C199, 200pcs
		32-bit increment/decrement count: C200-C235, 36pcs
		32-bit high speed count:C236-C255, 20pcs
Data register (D)	D0-D7999, 8000 points	
Local data register(V)	V0~V63, 64 points	
Variable address register(Z)	Z0~Z15, 16 points	
Special data register(SD)	SD0-SD255, 256 points	
Power-off retention register	M, S, D, C components can be saved, 320pcs bit components, 180pcs word components	
Storage media	EEPROM+FLASH	
High-speed counter	Single phase: 6 sets, 2×50KHz+4×10KHz	
	Two-phase: 2 sets, 1×30KHz+1×5KHz	
Pulse output	Y0~Y1, 2-channel independent 100KHz output	
Interruption resource	External input interrupt	16pcs (X0~X7, 8-channel support for rising and falling edges)
	High-speed count interrupt	6pcs
	Timed interrupt	3pcs
	Communication interrupt	8pcs
	Pulse interrupt	2pcs
Power loss interruption	1pcs	
Analogue potentiometer input	2pcs(0-255)	
Pulse capture	8-channel, X0-X1: 20μs, X2-X7: 100μs	
Digital filtering	X0-X7 are capable of digital filtering, filtering time (ms): 0, 8, 16, 32, 64. Others are capable of hardware filtering	
Communication port	3-channel (2-channel are RS-232, 1 channel is RS-232 / RS -485 optional)	

VC20 Series High Performance General Purpose PLC



VC20 series is a high-performance general-purpose small PLC, with powerful I/O extension capabilities and communication networking capabilities, it can be used for high-speed data processing and analogue processing, with capabilities of high stability, high reliability, large capacity, high-speed computing. It has powerful functions and high cost performance. Widely used in machine tools, construction machinery, textile, printing, metal processing, wire drawing equipment, plastic machinery, air conditioning, HVAC, food and beverage, engineering machinery, electronic equipment, underground, lift, pharmaceutical equipment and other industries.

High stability and reliability

- Ultra-wide operating voltage: AC85~280V.
- Strict three-proof treatment of the board, adapted to the harsh field environment
- User programme EEPROM permanent storage
- Ultra-strong environmental adaptability
- Excellent anti-interference

High speed and large capacity

- High computing speed — basic instruction: 0.09μs
- Large programme capacity — up to 12k steps without extension

Reliable programme security

- 8-digit multi-level password protection, unique password compression and encryption technology and stored in the PLC to effectively protect the user's intellectual property rights.

Real-time clock

- The main module has a built-in real-time clock (RTC) and provides a perpetual calendar function.

Superior I/O extension

- I/O points can be expanded up to 512 points.
- Expandable up to 8 special function modules

Abundant programming instructions

- Number of instructions
Basic instructions —32pcs
Application instructions — 221pcs

Convenient and fast programming function

- Three programming languages
Ladder diagrams, instruction tables, sequential function charts
- Online modification
Online editing, online downloading, online debugging
Online modification has no step limit and can be modified at will.
- Chinese programming
F1 single key intelligent help

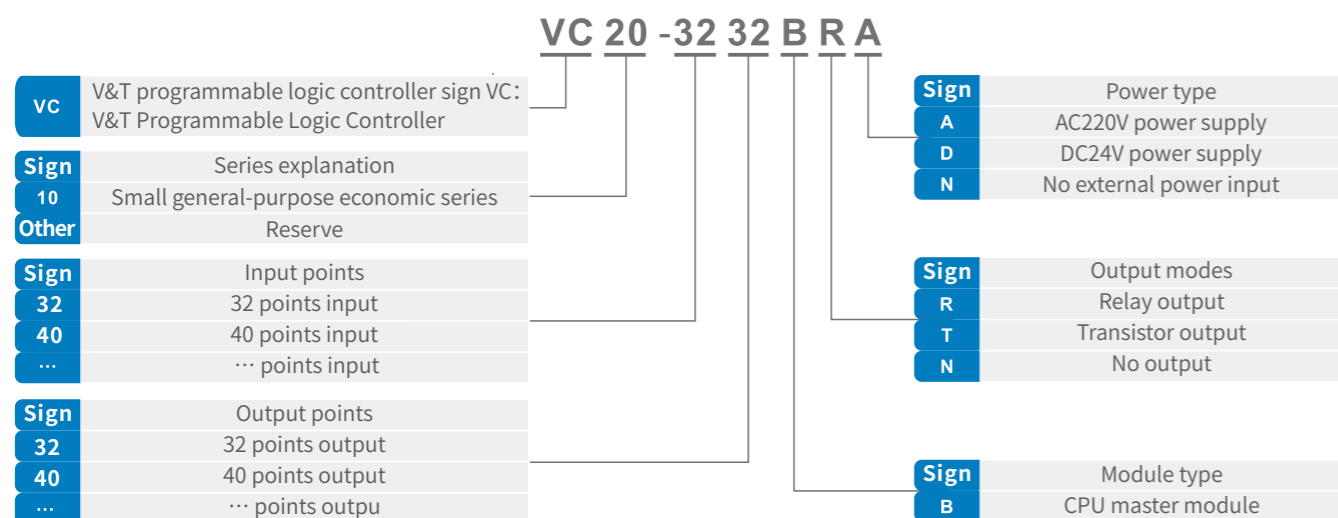

Selection Chart

Master Module

Product series	Product model	Description	Size
VC20	VC20-3232BRA	VC20 series 32-point input 32-point relay output master module (AC power supply)	228×90×82
VC20	VC20-3232BTA	VC20 series 32-point input 32-point transistor output master module (AC power supply)	228×90×82
VC20	VC20-4040BRA	VC20 series 40-point input 40-point relay output master module (AC power supply)	275×90×82
VC20	VC20-4040BTA	VC20 series 40-point input 40-point transistor output master module (AC power supply)	275×90×82

I/O Extension Module

Product series	Product model	Description	Size
VC20	VC20-0808ERN	VC20 series 8-point input 8-point relay output extension module	58×90×82
VC20	VC20-0808ETN	VC20 series 8-point input 8-point transistor output extension module	58×90×82
VC20	VC20-1600ENN	VC20 series 16-point input extension module	58×90×82
VC20	VC20-0016ERN	VC20 series 16-point relay output extension module	58×90×82
VC20	VC20-0016ETN	VC20 series 16-point transistor output extension module	58×90×82

Special Function Module

Product series	Product model	Description	Size
VC20	VC20-4AD	VC20 series 4-channel analogue input module	58×90×82
VC20	VC20-8AD	VC20 series 8-channel analogue input module	58×90×82
VC20	VC20-4DA	VC20 series 4-channel analogue output module	58×90×82
VC20	VC20-4PT	VC20 series 4-channel RTD module	58×90×82
VC20	VC20-8TC	VC20 series 8-channel thermocouple module	58×90×82
VC20	VC20-RS485	VC20 series RS485 communication module	32×90×82

Specifications and Technical Specifications

Master Module General Specifications

Item	Specification
Input voltage range	85 ~280VAC
DC output voltage	24VDC
Safety regulation	Designed according to IEC61131-2 standard
Working temperature	-5~55°C
Storage temperature	-40 ~70°C
Environment temperature	10 ~ 95% (non-condensing)
Protection level	IP30
Power hold	< 200ms

Master Module Output Interface Specifications

Item	Relay output port	Transistor output port
Power supply	250VAC, under 30VDC	5 ~ 24VDC
COM current	< 8A	< 2A
Circuit insulation	Relay mechanical insulation	Photocoupler insulation
Motion indication	Relay output contacts closed, LED on	Photocoupler is driven, LED on
Leakage current of open circuit	/	Less than 0.1 mA/30VDC
Min. load	5mA	2mA/5VDC
Max output current	Resistive load	Y0、Y1:0.3A/1 point Others: 0.3A/1 point 0.8A/4 points 1.2A/6 points 1.6A/8 points Above 8 points, total current increases 0.1A at each point increase
	Inductive load	220VAC, 80VA 7.2W/24VDC Others: 12W/24VDC
	Illumination load	220VAC, 100W Y0、Y1: 0.9W/24VDC Others: 1.5W/24VDC
	ON response time	20ms Max Y0、Y1: 5 μs Others: 0.5ms
	OFF response time	20ms Max
	Y0、Y1 max output frequency	/
	Output common terminal	Y0-COM0: Y1-COM1 : Y2、Y3-COM2: Y4-COM3: after Y10, Up to 1 common terminal for every 8 terminals, with each common terminal isolated from the other

Master Module Main Performance Specifications

Item	Specification	
Implementation method		Cycle scan
Programming method		Instruction, ladder diagram, sequential function diagram
Instruction Type	Basic instruction	32pcs
	Application instruction	221pcs
Implementation time	Basic instruction	0.09 μs
	Application instruction	Several μs~ Hundreds μs
Program capacity		12K steps
I/O points	Max extension	Switching input 256 points / Switching output 256 points
X	Input relay	X0~X377, 256 points, octal code
Y	Output relay	Y0~X377, 256 points, octal code
M	Auxiliary relay	M0-M1999, 2000 points
LM	Local auxiliary relay	LM0-LM63, 64 points
SM	Special auxiliary relay	SM0 ~SM255, 256 points
S	Status relay	S0-S991,992 points (S0-S19 initial step)
		S20-S991 ordinary step)
T	Timer	100ms T0 ~T209, 210 pcs
		10ms T210~T251,42pcs
		1ms T252~T255,4pcs
CC	Counter	16-bit incremental count C0~C199,200pcs
		bit increment/ decrement count C200 ~ C235, 36pcs
		32-bit high speed count C236~C255, 20pcs
D	Data register	D0 ~ D7999, 8000 points
SD	Special data register	SD0-SD255, 256 points
V	Local data register	V0-V63, 64 points
Z	Variable address register	Z0-Z15, 16 points
Power-off retention register		M、S、D、C、T components can be optionally saved in sections
Storage media		EEPROM+SRAM
Battery retention time		Three years
Pulse output		Y0~Y1,2-channel, 100KHz
External interrupt		X0~X7, 8-channel (Support top and bottom edge)
High-speed counter interrupt		6pcs
Timed Interrupt		3pcs
Pulse capture		8-channel
Communication port		2pcs (One is R5-232, one is R5-232 / R5-485 optional)

VC20H High Performance Motion Control PLC



The VC20H series is a high-performance motion control PLC with integrated 8×100KHz high-speed counting function and up to 6 high-speed pulse outputs up to 200KHz. Up to 32K programme storage capacity. With linear interpolation, circular interpolation, synchronous following, electronic gears and electronic cams and other sport control functions, it can achieve positioning control, trajectory control and synchronous motion control, and is suitable for robotics, textile, printing, dyeing and finishing, packaging, machine tools, woodworking machinery and other industries.

Dual-core processing for dramatically increased computing speed and high-speed performance

- MCU + FPGA dual-core processing, multi-task parallel operation, to solve the traditional small PLC can not achieve high-speed processing and sport control functions
- Basic instruction processing speed is less than 0.065 us

Ample resources to meet the requirements of complex multitasking programme

- Program capacity up to 32K steps
- New R element is added, which can be used as D element and has a capacity of 32K
- Variable table: 2000pcs, 40K space

Extraordinary high-speed processing capability

- Integrated 8-point simultaneous 100KHz high-speed counting
- Support single-phase single-ended counting, single-phase increment/decrement counting and dual-phase counting
- Support SPD frequency measurement, pulse capture and external rising/falling edge termination
- 4-channel simultaneous dual-phase counting up to 50KHz, supports 4 quadruple frequency technology
- Integrated 6-axis high-speed pulse output up to 200KHz
- Support PWM (Pulse Width Modulation), PTO (Pulse Train Output) and interpolated pulse outputs

Enhanced positioning control, precise trajectory control, advanced synchronised sport control

Superior extension capability, powerful communication and networking capability

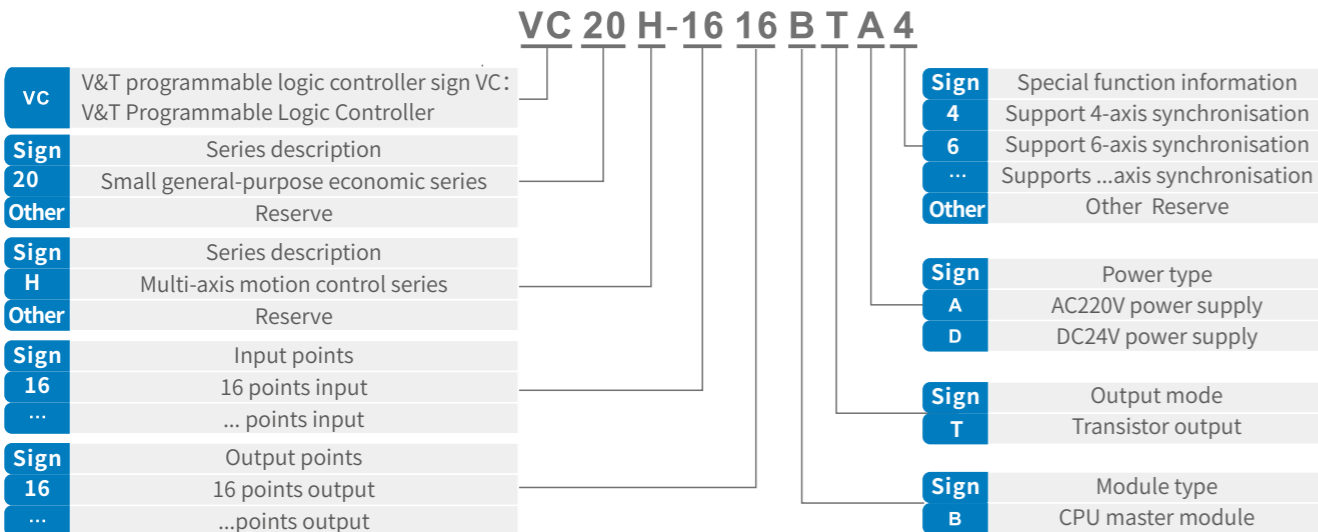

Selection Chart

Master Module

Product series	Product model	Description	Size
VC20H	VC20H-1616BTA4	VC20H series 16-point input 16-point transistor output master module (AC power supply, 4-axis positioning)	170×90×82
VC20H	VC20H-1616BTA6	VC20H series 16-point input 16-point transistor output master module (AC power supply, 6-axis positioning)	170×90×82

General Specifications

Item	Specification
Input voltage range	85 ~280VAC
DC output voltage	24VDC
Safety regulation	Designed according to IEC61131-2 standard
Working temperature	-5~55°C
Storage temperature	-40~70°C
Environment temperature	10 ~ 95% (non-condensing)
Protection level	IP30
Power hold	< 200ms

Master Module Output Interface Specifications

Item	Transistor output terminal	
External power	5-24VDC	
Circuit insulation	Photocoupler insulation	
Motion indication	Photocoupler is driven, LED on	
Leakage current of open circuit	Less than 0.1mA/30VDC	
Min. load	5mA (5-24VDC)	
Max output current	Resistive load	Y0、Y7: 0.3A/1 point Others:0.3A/1 point 0.8A/4 points 1.2A/6 points 1.6A/8 points
	Inductive load	7.2W/24VDC
	Illumination load	Y0、Y7: 0.9W/24VDC Others: 1.5W/24VDC
Response time	ON response time	Y0、Y7: less than 5 us / more than 10ma
	OFF response time	Others: less than 0.5ms/ more than 100ma
Max output frequency	Y0-Y3: each channel 200KHz; Y4-Y7: each channel 100KHz	
Output common terminal	Y0、Y1-COM0; Y2、Y3-COM1; Y4、Y5-COM2; Y6、Y7-COM3;Y10-Y13-COM4; Y14-Y17-COM5, each common terminal is isolated from each other	
Fuse protection	No	

Main Performance Specifications

Name	Specification and description		
IO configuration	Max. number of IO points	512 points	
	Number of special function modules	Max. 8	
Program memory	User program capacity	32K steps	
	Data block capacity	8000 D unit, 32768 R unit	
Instruction speed	Basic instruction	0.065µs	
	Application instruction	Several µs- Hundreds µs	
Soft component configuration	Input&output relay (X, Y)	256 in 256 out (input X0-X377, output Y0-Y377)	
	Auxiliary relay (M)	10240 points (M0-M10239)	
	Local auxiliary relay (LM)	64 points (LM0 ~ LM63)	
	Special auxiliary relay (SM)	512 points (SM0-SM511)	
	Status relay(S)	4096 points (S0 ~ S4095)	
	Timer(T)	512 points (T0-T511)	100ms precision: T0 -T209, 210pcs
			10ms precision: T210~T479, 270pcs
			1ms precision: T480~T511, 32pcs
	Counter (C)	262 points (C0-C255, C301-C306)	16-bit normal increment/ decrement counters: C0-C199,200pcs
			32-bit normal increment/decrement counters: C200-C235, 36pcs
32-bit High Speed Counter: C236-C255, C301-C306, 26pcs			
Data register(D)	8000 points (D0 ~ D7999), 32768 points (R0 ~ R32767)		
Local data register(V)	64 points (V0-V63)		
Variable address register(Z)	16 points (Z0-Z15)		
Special data register(SD)	512 points (SD0-SD511)		
Interruption resource	External input interrupt	16pcs	
	High-speed counter interrupt	8pcs	
	Internal timer interrupt	3pcs	
	Communication interrupt	12pcs	
	High-speed output completion interrupt	6pcs	
	Power failure and interrupt	1pcs	
	Interpolation completion interrupt	3pcs	
	Passing position interrupt	6pcs	
Communication function	Communication port	3 asynchronous serial communication ports PORT0: RS232; PORT1: RS485; PORT2: RS485	
	Communication protocol	Programming port protocol, Modbus protocol, and free port protocol can form 1:N and N:N networks	
Motion control function	High-speed counter	X0-X7	channel single phase input: 8*100KHz 4-channel AB phase input: 4*50KHz, supports quad-clocking
	Pulse output	Y0/Y1	200KHz group output
		Y2/Y3	200KHz group output
		Y4、 Y5	100KHz independent output, support PWM mode output
	Single-axis drive	Y6、 Y7	100KHz independent output, support PWM mode output
	Interpolation function	All 6 axes support linear interpolation and circular interpolation.	
Synchronisation function	Position following		
Special function	Input filtering	X0-X7 provide digital filtering	
	User program protection	Upload password	Provide 3 forms of password, the password is not more than 8 letters or numbers, case sensitive
		Download password	
		Monitor password	
	Other protective measures	Provide prohibit formatting, prohibit uploading, subroutine password protection function	
Data power-off retention register	Real-time clock	Data retention for three years, no loss of data in the process of battery replacement, no loss of data within 30S	
	Power-off retention register element	Component saving range is set in the system block, all M, S, D, C, T components can be saved	

Extracts of Programming Instructions

	Instruction	Function description	
Basic instruction	LD	NO contact power-flow loading	
	LDI	NC contact power-flow loading	
	AND	NO contact power-flow and	
	ANI	NC contact power-flow and	
	OR	NO contact power-flow or	
	ORI	NC contact power-flow or	
	OUT	Power-flow output	
	SET	Set	
	RST	Reset	
	ANB	Power-flow block and	
	ORB	Power-flow block or	
	INV	Power-flow block inverse	
	NOP	No operation	
	MPS	Output power-flow input stack	
	MRD	Read output power-flow stack top value	
	MPP	Output power-flow stack pop off	
	MC	Main control	
	MCR	Main control reset	
	EU	Power flow rising edge detection	
	ED	Power flow trailing edge detection	
	TON	On-delay timing	
	TOF	Off-delay timing	
	TMON	Monostable timing	
	TONR	On-delay remember timing	
	CTU	16-bit counter counting up	
CTR	16-bit counter loop cycle counting		
Program control instruction	DCNT	32-bit counting	
	LBL	Jump label definition	
	CJ	Conditional jump	
	CALL	Calling a subprogram	
	CSRET	Conditional return from user subprogram	
	CFEND	Conditional end from user main program	
	CIRET	Conditional return from user interrupt subprogram	
	FOR	Cycle	
	NEXT	Return from cycle	
	WDT	User program watchdog reset	
	STOP	User program stop	
	EI	Enable interrupt	
	DI	Disable interrupt	
	SFC instruction	STL	SFC state load
		SET Sxx	SFC state shift
OUT Sxx		SFC state jump	
RST Sxx		SFC state reset	
RET		SFC program end	
Data transmission instruction		MOV	Move word data transmission
		DMOV	Move double word data transmission
	RMOV	Move floating point number data transmission	
	BMOV	Move data block transmission	
	SWAP	High-low Swap bytes	
	Data stream	XCH	Swap bytes
		DXCH	Exchange double word
		FMOV	Fill data block
		DFMOV	Fill data block double word
		WSFR	Shift right word
WSFL		Shift left word	
PUSH		Push	
Integer/ Long integer math instruction	FIFO	First-in-first-out	
	LIFO	Last-in-first-output	
	ADD	Integer math	
	DADD	Add double integer	
	SUB	Subtract integer	
	DSUB	Subtract double integer	
	INC	Increment integer	
	DINC	Increment double integer	
	DEC	Decrement integer	
	DDEC	Decrement double integer	
	MUL	Multiply integer	
	DMUL	Multiply double integer	
	DIV	Divide integer	
	DDIV	Divide double integer	
	VABS	Integer absolute value	
	DVABS	Double integer absolute value	
	NEG	Negative integer	
	DNEG	Negative double integer	
	SQT	Square root integer	
	DSQT	Square root double integer	
Floating point number math instruction	SUM	Sum integer	
	DSUM	Sum double integer	
	RADD	Add floating point number	
	RSUB	Subtract floating point number	
	RMUL	Multiply floating point number	
	RDIV	Divide floating point number	
	RVABS	Floating point number absolute value	
	RNEG	Negative floating point number	
	RSQT	Square root floating point number	
	SIN	Floating point number SIN	
	COS	Floating point number COS	
	TAN	Floating point number TAN	
	LN	Floating point number LN	
	EXP	Floating point number EXP	
	POWER	Floating point number exponentiation	
RSUM	Sum floating point number		

Extracts of Programming Instructions

	Instruction	Instruction Function Description
Word/ double- word logical operation	WAND	AND word
	DWAND	AND double word
	WOR	OR word
	DWOR	OR double word
	WXOR	Exclusive-OR word
	DWXOR	Exclusive-OR double word
	WINV	NOT word
	DWINV	NOT double word
Bit shift rotation instruction	ROR	16-bit circular shift right
	DROR	32-bit circular shift right
	ROL	16-bit circular shift left
	DROL	32-bit circular shift left
	RCR	16-bit carry circular shift right
	DRCR	32-bit carry circular shift right
	RCL	16-bit carry circular shift left
	DRCL	32-bit carry circular shift left
	SHR	16-bit shift right word
	DSHR	32-bit shift right word
	SHL	16-bit shift left
	DSHL	32-bit shift left
	SFTL	Shift left byte
	SFTR	Shift right byte
Enhanced bit logic instruction	DECO	Decode
	ENCO	Encode
	BITS	Counting ON bit in word
	DBITS	Counting ON bit in double word
	ZRST	Batch bit reset
	ZSET	Set batch bit
High- speed I/O instruction	HCNT	High-speed counter drive
	DHSCS	High-speed counting compare set
	DHSCR	High-speed counting compare reset
	DHSCI	High-speed counting compare interrupt trigger
	DHSZ	High-speed counting zone compare
	DHST	High-speed counting table compare
	DHSP	High-speed counting table compare pulse output
	SPD	Pulse detection
	PLSY	Count pulse output
	PLSR	Count pulse with acceleration/deceleration output
	PWM	PWM pulse output
PLS	Pulse output instruction of envelope	
Control calculation instruction	PID	PID
	RAMP	Ramp wave signal output
	TRIANGLE	Triangle wave signal output instruction
	HACKLE	Hackle wave signal output

	Instruction	Instruction Function Description
Peripheral instruction	FROM	Read word form special module buffer register
	DFROM	Read double word form special module buffer register
	TO	Write word to special module buffer register
	DTO	Write double word to special module buffer register
	VRRD	Read analog potentiometer value
	REFF	Set input filtering constant
	REF	Instant refresh I/O
	EROMWR	EEPROM write
Position instruction	ABS	Read current value
	ZRN	Zero return
	PLSV	Variable speed pulse output
	DRVI	Relative position control
	DRVA	Absolute position control
Real time clock instruction	TRD	Read real-time clock
	TWR	Write real-time clock
	TADD	Add clock
	TSUB	Subtract clock
	HOUR	Timing list
Comparison contact instruction	LD =	Compare integer LD=
	LDD =	Compare double integer LDD=
	LDR =	Compare floating point number LDR=
	LD >	Compare integer LD>
	LDD >	Compare double integer LDD>
	LDR >	Compare floating point number LDR>
	LD >=	Compare integer LD>=
	LDD >=	Compare double integer LDD>=
	LDR >=	Compare floating point number LDR>=
	LD <	Compare integer LD<
	LDD <	Compare double integer LDD<
	LDR <	Compare floating point number LDR<
	LD <=	Compare integer LD<=
	LDD <=	Compare double integer LDD<=
	LDR <=	Compare floating point number LDR<=
	LD <>	Compare integer LD<>
	LDD <>	Compare double integer LDD<>
	LDR <>	Compare floating point number LDR<>
	AND =	Compare integer AND=
	ANDD =	Compare double integer ANDD=
ANDR =	Compare floating point number ANDR=	
AND >	Compare integer AND>	
ANDD >	Compare double integer ANDD>	
ANDR >	Compare floating point number ANDR>	

Extracts of Programming Instructions

	Instruction	Instruction Function Description
Comparison contact instruction	AND >=	Compare integer AND>=
	ANDD >=	Compare double integer ANDD>=
	ANDR >=	Compare floating point number ANDR>=
	AND <	Compare integer AND<
	ANDD <	Compare double integer ANDD<
	ANDR <	Compare floating point number ANDR<
	AND <=	Compare integer AND<=
	ANDD <=	Compare double integer ANDD<=
	ANDR <=	Compare floating point number ANDR<=
	AND <>	Compare integer AND<>
	ANDD <>	Compare double integer ANDD<>
	ANDR <>	Compare floating point number ANDR<>
	OR =	Compare integer OR=
	ORD =	Compare double integer ORD=
	ORR =	Compare floating point number ORR=
	OR >	Compare integer OR>
	ORD >	Compare double integer ORD>
	ORR >	Compare floating point number ORR>
	OR >=	Compare integer OR>=
	ORD >=	Compare double integer ORD>=
ORR >=	Compare floating point number ORR>=	
Numeric conversion instruction	OR <	Compare integer OR<
	ORD <	Compare double integer ORD <
	ORR <	Compare floating point number ORR<
	OR <=	Compare integer OR<=
	ORD <=	Compare double integer ORD<=
	ORR <=	Compare floating point number ORR<=
	OR <>	Compare integer OR<>
	ORD <>	Compare double integer ORD<>
	ORR <>	Compare floating point number ORR<>
	ITD	Integer to double integer
	DTI	Double integer to integer
	FLT	Integer to floating point number
	DFLT	Double integer to floating point number
INT	Floating point number to integer	
DINT	Floating point number to double integer	
BCD	Word to 16-bit BCD	
DBCD	Double word to 32-bit BCD	
BIN	16-bit BCD to word	
DBIN	32-bit BCD to double word	
GRY	Word to 16-bit gray code	
DGRY	Double word to 32-bit gray code	
GBIN	16-bit gray code to word	

	Instruction	Instruction Function Description
Numeric conversion instruction	DGBIN	32-bit gray code to double word
	SEG	Word to 7-segment encode
	ASC	ASCII Code conversion
	ITA	Hexadecimal integer-ASCII conversion
	ATI	ASCII -hexadecimal integer conversion
Word contact instruction	BLD	Word bit contactor LD
	BLDI	Word bit contactor LDI
	BAND	Word bit contactor AND
	BANI	Word bit contactor ANI
	BOR	Word bit contactor OR
	BORI	Word bit contactor ORI
	BSET	Word bit coil set
	BRST	Word bit coil reset
	BOUT	Word bit coil output
Communication instruction	Modbus	MODBUS master station communication
	XMT	Free-port sending (XMT)
	RCV	Free-port receiving (RCV)
	EVFWD	MDI forward rotation
	EVREV	MDI reverse rotation
	EVDFWD	MDI touch forward rotation instruction
	EVDREV	MDI touch reverse rotation
	EVSTOP	Inverter stop
	EVFRQ	MDI set frequency n
	EVWRT	MDI write single register value
	EVRDST	MDI read status
EVRD	MDI read single register value	
Check instruction	CCITT	CCITT check
	CRC16	CRC16 check
	LRC	LRC check
Date comparison instruction	DCMP =	Compare date=
	DCMP >	Compare date>
	DCMP <	Compare date<
	DCMP >=	Compare date>=
	DCMP <=	Compare date<=
Time comparison instruction	DCMP <>	Compare date<>
	TCMP =	Compare time=
	TCMP >	Compare time>
	TCMP <	Compare time<
	TCMP >=	Compare time>=
	TCMP <=	Compare time<=
	TCMP <>	Compare time<>

DP-2000 Series HMI



VT DP-2000 series HMI has advantages of high-definition, high-brightness, full-viewpoint display, the max. viewpoint is 170°. It has not only powerful computing performance, fast complex engineering page switching, but also has more good UI controls, excellent human-computer interaction experience. It supports U disk to update HMI firmware, screen program, recipe data, etc., when used with VC series PLC, it can penetrate to update PLC program, which is convenient for the maintenance of field equipment.

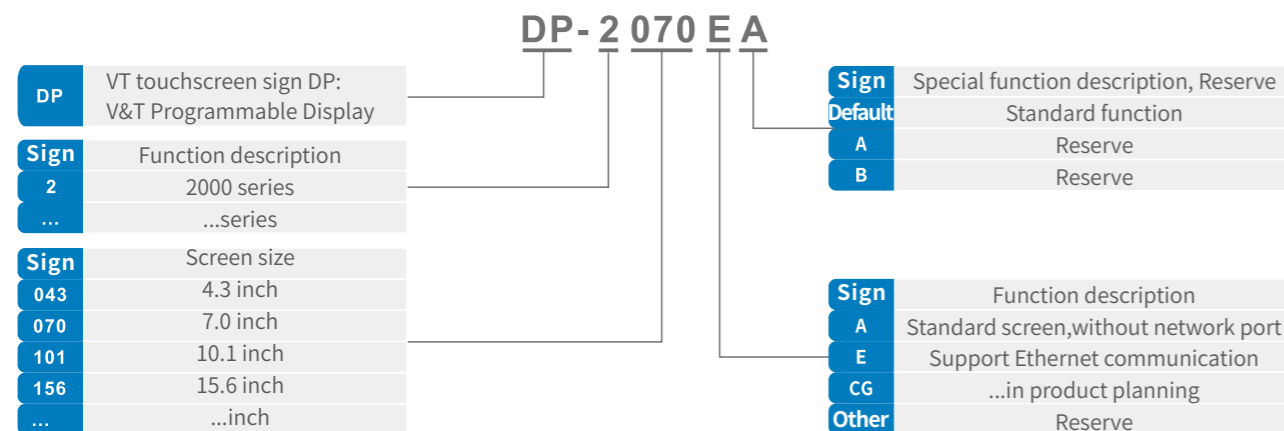

DP-2000 Series Touch Screen Basic Parameters

Model	DP-2043AA	DP-2070AA	DP-2070EA	DP-2101EA	DP-2156EA
Machine size	138*86*32	204*145*44.5	204*145*34	273*213*36	394*256*36
Hole Size	132*80mm	192*138mm	192*138mm	260*202mm	380*245mm
Screen size	4.3" (16:9) TFT	7.0" (16:9) TFT	7.0" (16:9) TFT	10.1" (16:9) TFT	15" (16:9) TFT
Resolution	480*272	800*480	1024*600		1920*1080
Brightness	250cd/m2	250cd/m2	350cd/m2	400cd/m2	250cd/m2
CPU processor	ARM 720MHz	ARM Cortex A8 600MHz	4 core 1.2GHz, ARM Cortex-A7		1 G RAM Cortex A8
Flash	128MB		4GB EMMC		256MB
RAM	64MB DDR3	64MB DDR3	256MB DDR3		512MB DDR3
SD card slot	No		Support		Support TF card
Download port	USB download, U flash disk		USB/U flash disk/Ethernet		
Ethernet port	No		Support		
Can communication port	No				
Serial port	COM1: RS232/RS422/RS485		COM1: RS232/RS422/RS485		COM1: RS232/RS422/RS485
	COM3: RS232		COM2: RS485		COM2: RS485 COM2: RS458/422
	Third serial port not supported		COM3: RS232		COM3: RS232
4G	Not support		Support optional		
WiFi	Not support				
Backlight type	LED				
Backlight life	≥40000h				
Display colour	24-colour	16-colour	24-colour		16-colour
Touch panel	4-wire industrial resistive (surface hardness is 4H)				
Working environment temperature	0°C~50°C (non-freezing). Prohibit working under strong UV environments (e.g. direct sunlight)				
Working environment humidity	10~90%RH (non-condensing)				
Storage environment temperature	-20°C~60°C (non-freezing)				
Vibration resistance	10~25Hz (X,Y,Z direction 2G/30 min)				
Shell material	Engineering plastic ABS				Aluminium alloy
RTC perpetual calendar	Support				
USB Host (U flash disk)	Support				
Rated power	<5W	<10W		<18W	
Rated voltage	DC 24V (Range: DC9~28V)				DC 24V (Range: DC18~28V)
Cooling method	Natural air-cooling				
CE&RoHS	Comply with EN61000-6-6:2005; EN61000-6-4:2007; RoHS, lightning surge ±1KV, group pulse ±2KV; electrostatic contact 4KV, air discharge 8KV				
Withstand voltage test	1000V AC, 1min				
Protection level	IP65 (front panel), machine back-shell meets IP20				

VC Series Multi-Channel Intelligent Thermostat



VC Multi-Channel Intelligent Thermostat is a modular temperature controller, small size, easy to install. It can be operated independently, but also can be used in conjunction with PLC, especially suitable for multi-channel temperature control occasions. Compared with the temperature control table, it has the features of space saving, easy data exchange, remote monitoring and cost-effective. Widely used in wave soldering, reflow soldering, bottle blowing machine, plastic absorbing machine, extruder, plastic machinery and other industries.

Product features

- High precision, intelligent.
- Heating and cooling dual PID control function, upper and lower limits, deviation and other 14 kinds of alarm functions.
- Adopting advanced artificial intelligence regulation technology and fuzzy algorithm, with functions of self-tuning and multi-segment temperature setting to achieve high-precision temperature control.

Convenient and easy to use

- Providing special software for temperature controllers, which makes it easy for users to set up and debug.
- Through Modbus and other protocols, it is easy to exchange data between PLC and HMI, PLC and computer.
- Integrated multi-channel temperature control, temperature control table replacement, to facilitate centralised data management. Compared with the temperature control table, it has advantages of high cost-effective, function-rich, easy to install, space-saving and simple programming and so on.

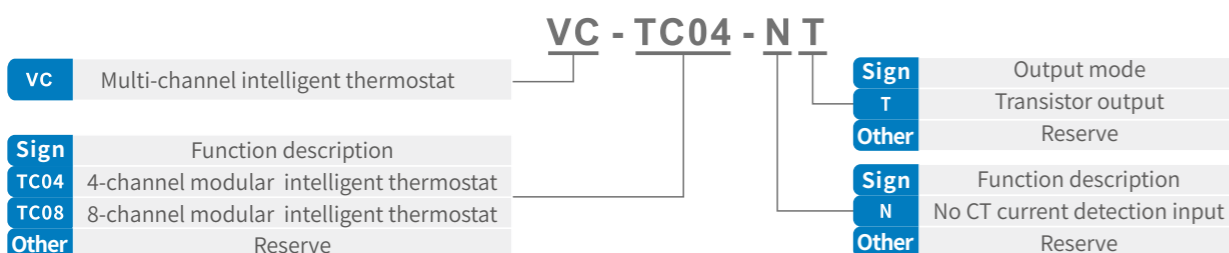

Selection Chart

Product Series	Product Model	Description	Size
VC	VC-TC04-NT	VC series 4-channel thermostat	61×90×75
VC	VC-TC08-NT	VC series 8-channel thermostat	61×90×75

Main Performance Specifications

Item	Specification
Power	24VDC, max. power consumption: VC-TC04-NT: 90mA; VC-TC08-NT: 120mA
Input type	Thermocouple type: K, J, E, N, T, R, S (Applicable to all channels)
	RTD type: Pt100, Cu100, Cu50 (Applicable to all channels)
Output mode	Open collector output
	Power supply: 5V-24V
	Max. power supply: 30V
	Max. load current: 0.3A/24VDC
	Leakage current of open circuit: <0.1mA/30VDC
	Min. load: 5mA (5VDC-24VDC)
Sample period	8-channel max. execution time is 500ms (The unused channels are not converted, and the cycle time is reduced by 125ms for each group of corresponding channels (1 and 5, 2 and 6, 3 and 7, 4 and 8).)
Control period	1-100s, default value is 30s
Control method	ON/OFF control, PI control, PID control
Precision	±0.5% input range ±1 bit
Isolation	Sampling channels are isolated from the power supply, sampling channels are isolated from the outputs, and channels are not isolated from each other
Communication	1 isolated RS485, supports Modbus protocol